

SMD Type 3000 W

■ Features

1. For surface mounted applications
2. RoHS compliant and halogen-free
3. Reliable low cost construction utilizing molded plastic technique
4. Glass passivated chip junction
5. Both bi-directional and uni-directional devices are available
6. Fast response time
7. Low leakage
8. Excellent clamping capability
9. 3000W peak pulse power capability with a 10/1000 μ s waveform, repetitive rate (duty cycle): 0.01%
10. High reliability application and automotive grade AEC Q101 qualified



■ Recommended Applications

1. Telecommunication
2. Computer
3. Industrial device
4. Consumer electronic device
5. Automotive

■ Mechanical Data

1. Case: DO-214AB (SMC), molded plastic meets UL flammability rating 94V-0
2. Terminal: Matte Tin-plated leads, solderable per MIL-STD-750, Method 2026
3. Polarity: The band denotes cathode (Note: no polarity indicator for bi-directional devices)

■ Part Number Code

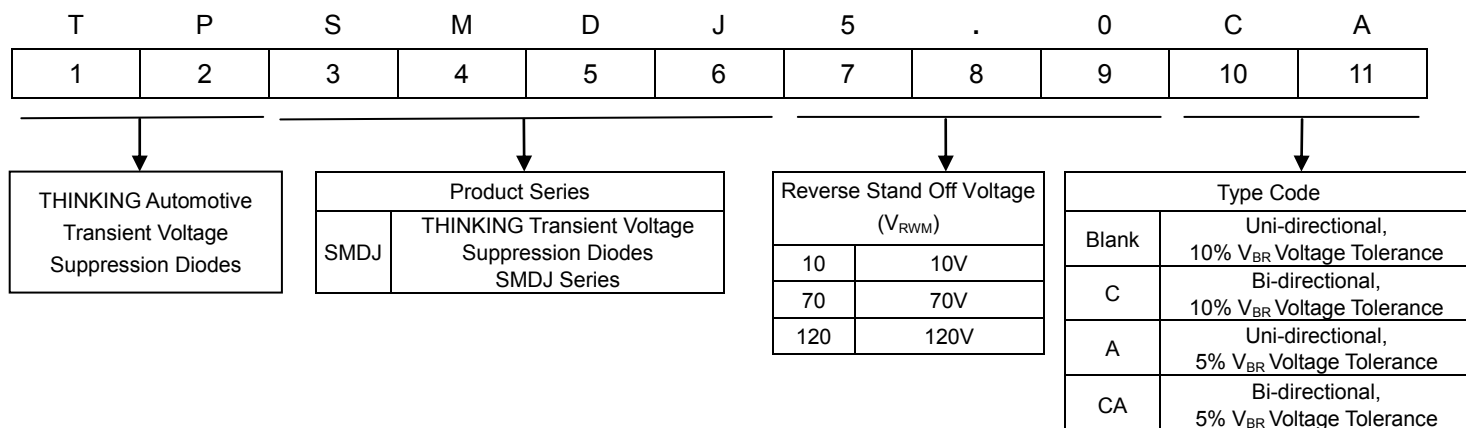

Transient Voltage Suppression Diodes: TPSMDJ Series

SMD Type 3000 W



Structures and Dimensions

SMC-DO214AB

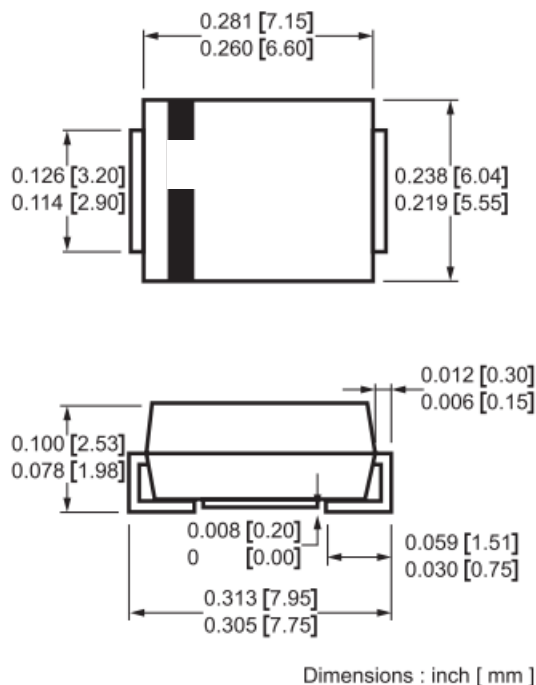

Maximum Rating ($T_A=25^\circ\text{C}$ unless otherwise noted)

Parameter	Symbol	Value	Unit
Peak pulse power dissipation at $T_A=25^\circ\text{C}$ by 10/1000 μs waveform (Note1).	P_{PPM}	3000	W
Peak pulse current of on 10/1000 μs waveform (Note1)	I_{PPM}	See Table	A
Peak forward surge current, 8.3ms single half sine wave on rated load (Note 2)	I_{FSM}	300	A
Power dissipation on infinite heatsink at $T_L=75^\circ\text{C}$	P_D	6.5	W
Operating junction and storage temperature range	T_J, T_{STG}	-55~+150	$^\circ\text{C}$

Note: 1. Please refer to Fig. 5 for non-repetitive current pulse, and Fig. 1 for derated above $T_A = 25^\circ\text{C}$

2. 8.3ms single half sine-wave, or square wave that has a maximum of 4 pulses per minute.

SMD Type 3000 W

■ Electrical Characteristics ($T_A=25^\circ\text{C}$ unless otherwise noted)

Part No. (Uni)	Part No. (Bi)	Reverse Stand off Voltage	Breakage Voltage VBR @ IT		Test Current	Maximum Clamping Voltage VC @ Ipp	Maximum Peak Pulse Current	Maximum Reverse Leakage IR @VRWM	Marking Code	
			VRWM (V)	Min(V)					Max(V)	IT(mA)
TPSMDJ10A	TPSMDJ10CA	10	11.1	12.3	1	17	176.47	15	PDXA	DDXA
TPSMDJ11A	TPSMDJ11CA	11	12.2	13.5	1	18.2	164.84	2	PDZA	DDZA
TPSMDJ12A	TPSMDJ12CA	12	13.3	14.7	1	19.9	150.75	2	PEEA	DEEA
TPSMDJ13A	TPSMDJ13CA	13	14.4	15.9	1	21.5	139.53	2	PEGA	DEGA
TPSMDJ14A	TPSMDJ14CA	14	15.6	17.2	1	23.2	129.31	2	PEKA	DEKA
TPSMDJ15A	TPSMDJ15CA	15	16.7	18.5	1	24.4	122.95	2	PEMA	DEMA
TPSMDJ16A	TPSMDJ16CA	16	17.8	19.7	1	26	115.38	2	PEPA	DEPA
TPSMDJ17A	TPSMDJ17CA	17	18.9	20.9	1	27.6	108.7	2	PERA	DERA
TPSMDJ18A	TPSMDJ18CA	18	20	22.1	1	29.2	102.74	2	PETA	DETA
TPSMDJ19A	TPSMDJ19CA	19	21.1	23.3	1	30.8	97.47	2	PEBA	DEBA
TPSMDJ20A	TPSMDJ20CA	20	22.2	24.5	1	32.4	92.59	2	PEVA	DEVA
TPSMDJ22A	TPSMDJ22CA	22	24.4	26.9	1	35.5	84.51	2	PEXA	DEXA
TPSMDJ24A	TPSMDJ24CA	24	26.7	29.5	1	38.9	77.12	2	PEZA	DEZA
TPSMDJ26A	TPSMDJ26CA	26	28.9	31.9	1	42.1	71.26	2	PFEA	DFEA
TPSMDJ28A	TPSMDJ28CA	28	31.1	34.4	1	45.4	66.08	2	PFGA	DFGA
TPSMDJ30A	TPSMDJ30CA	30	33.3	36.8	1	48.4	61.98	2	PFKA	DFKA
TPSMDJ33A	TPSMDJ33CA	33	36.7	40.6	1	53.3	56.29	2	PFMA	DFMA
TPSMDJ36A	TPSMDJ36CA	36	40	44.2	1	58.1	51.64	2	PFPA	DFPA
TPSMDJ40A	TPSMDJ40CA	40	44.4	49.1	1	64.5	46.51	2	PFRA	DFRA
TPSMDJ43A	TPSMDJ43CA	43	47.8	52.8	1	69.4	43.23	2	PFTA	DFTA

Note:

1. Add suffix "C" or "CA" after part number to specify Bi-directional devices.
2. For bidirectional type having V_{RWM} of 10 volts and under, the I_R limit is doubled.

SMD Type 3000 W

■ Rate and Characteristic Curve ($T_A=25^\circ\text{C}$ unless otherwise noted)

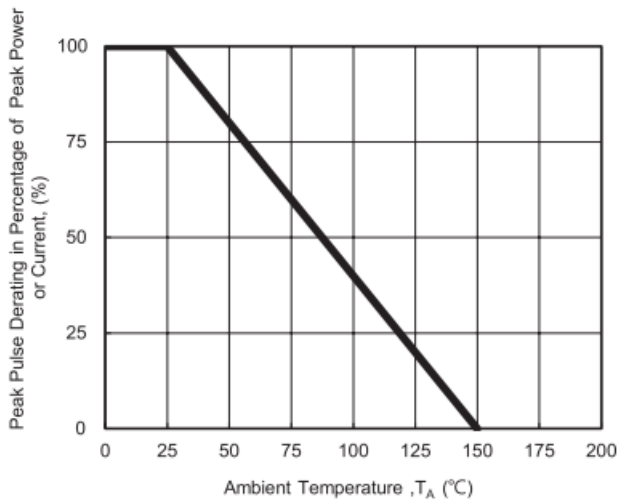

Fig. 1 - Pulse Derating Curve

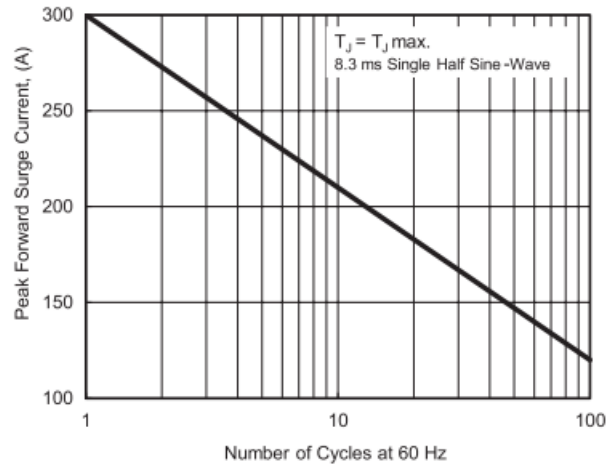

Fig. 2 - Maximum Non-Repetitive Surge Current

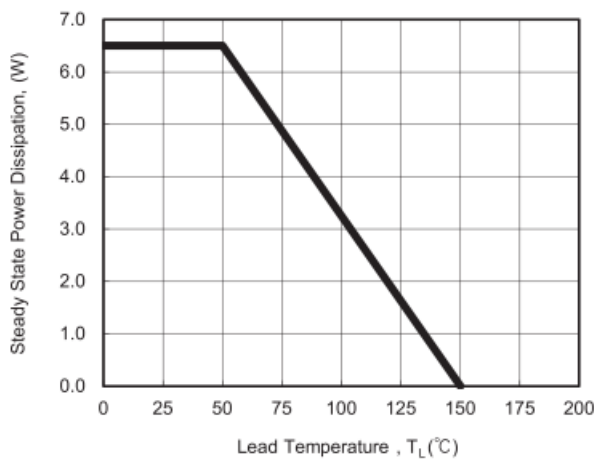

Fig. 3 - Steady State Power Derating Curve

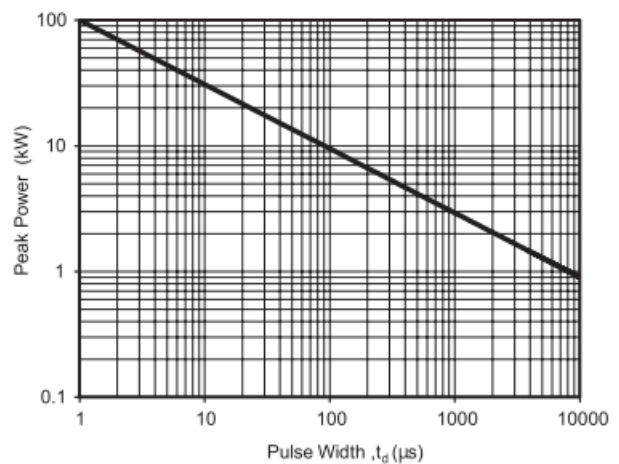

Fig. 4 - Peak Pulse Power Rating Curve

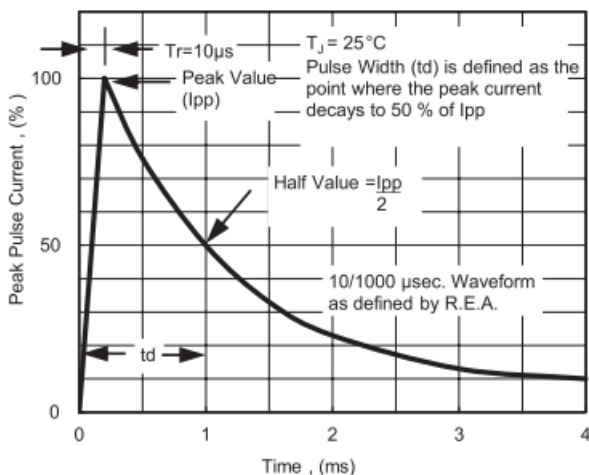

Fig. 5 - Pulse Waveform

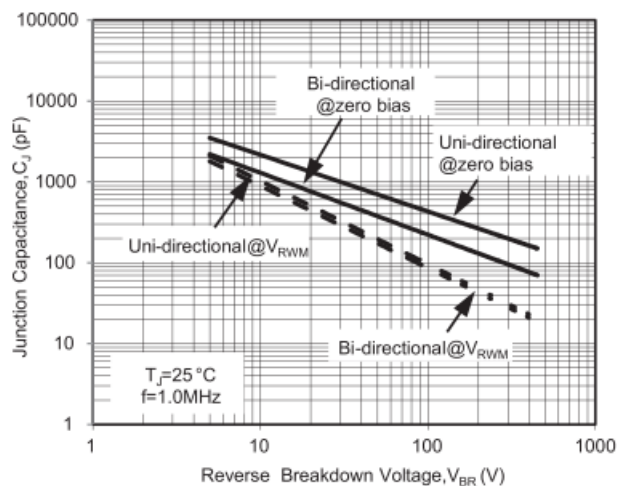

Fig. 6 - Typical Junction Capacitance

Transient Voltage Suppression Diodes: TPSMDJ Series

SMD Type 3000 W



IR-reflow soldering profile

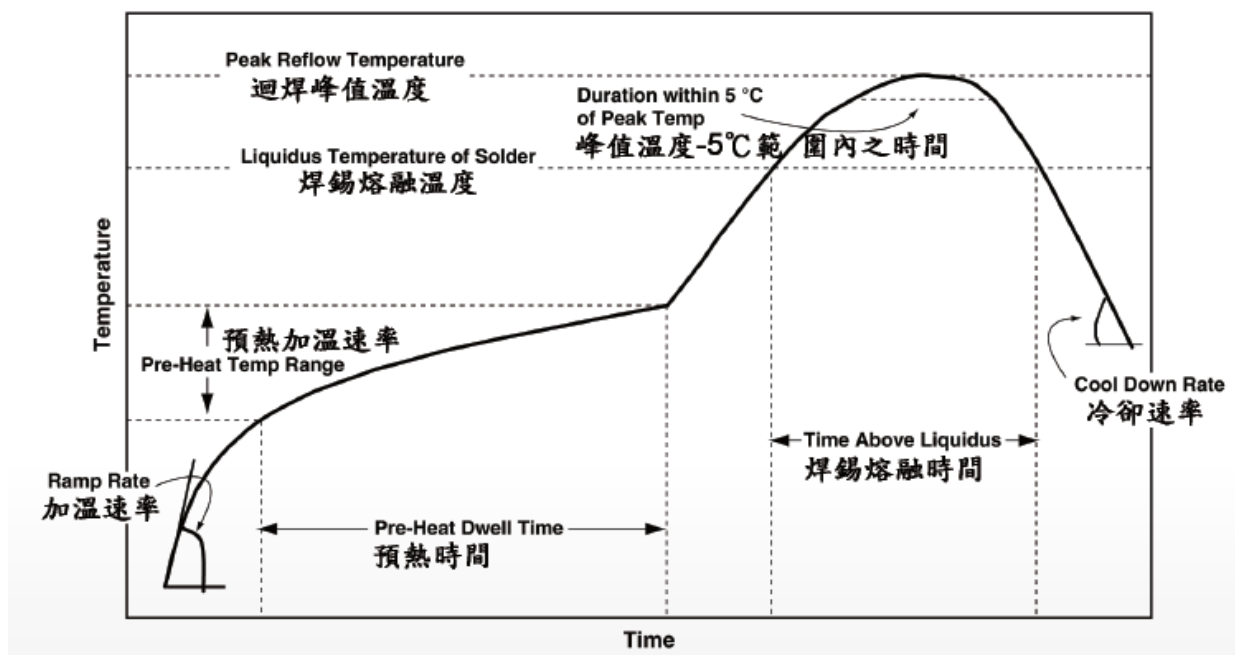

LEAD(Pb)-FREE SOLDER(SnAgCu) REFLOW PROFILE ATTRIBUTES	
PROFILE ATTRIBUTE	PROFILE ATTRIBUTE
Peak Reflow Temperature	250(+10/-5)°C
Time within 5°C of Peak Temperature	30s max
Liquidus Temperature of Solder	217°C
Cool Down Rate	6 °C/s max
Time above Liquidus	60s to 150s
Pre-heat Temperature Range	150°C to 200°C
Pre-heat Dwell Time	60s to 120s
Maximum Ramp Rate	3 °C/s max

Transient Voltage Suppression Diodes: TPSMDJ Series

SMD Type 3000 W



■ Packaging

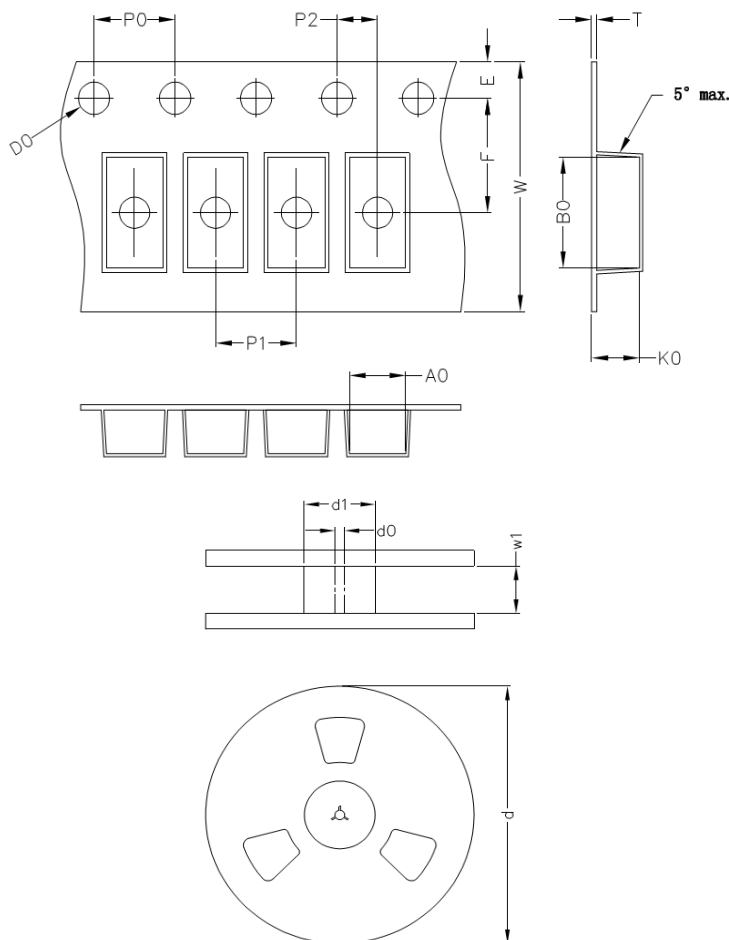

Item	Symbol	DO-214AB (SMC) Unit: mm
Carrier width	A0	6.05
Carrier length	B0	8.31
Carrier depth	K0	2.54
Sprocket hole	D0	1.55
Sprocket hole position	E	1.75
Punch hole position	F	7.5
Sprocket hole pitch	P0	4
Carrier pitch	P1	8
Embossment center	P2	2
Tape thickness	T	0.4
Tape width	W	16
Reel outside diameter	d (13")	330
Reel inner diameter	d1	50
Feed hole diameter	d0	13.5
Reel inner width	w1	18.4

Note: The tolerance of carrier tape and top cover is ± 0.1 mm, and the tolerance of reel is ± 2 mm

■ Quantity

MPQ: 3,000pcs

Package Type	Reel Size	Reel	Inner Box
	inch	Kpcs	Kpcs
DO-214AB	13	3	6

■ Warehouse Storage Conditions of Product

- Storage Condition:
 - Storage Temperature: 15~30°C
 - Relative Humidity: $\leq 75\%$ RH
 - Keep away from corrosive atmosphere and sunlight.
- Period of Storage: 1 year.